

Installation & Programming Guide

Classic & Modern Styles

Electronic Deadbolt Locksets

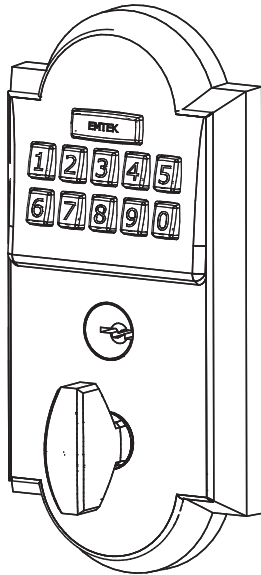

Classic Style

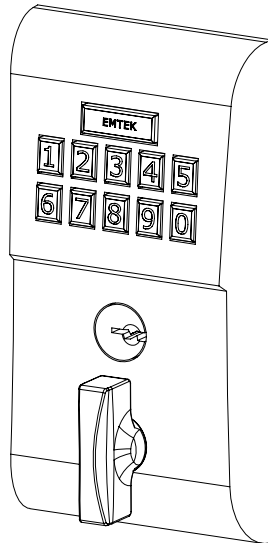

Modern Style

What's in the Box

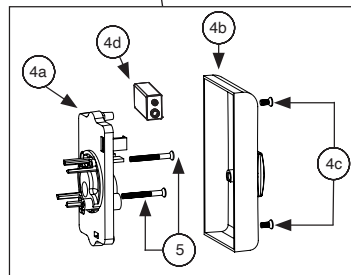
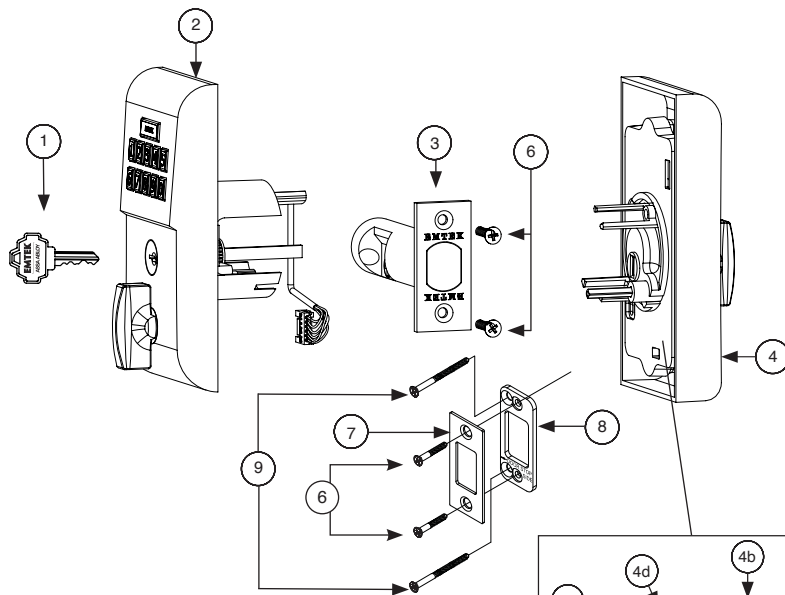

ITEM NO.	DESCRIPTION	QTY.
1	Key	2
2	Outside Trim Plate Assembly	1
3	Deadbolt Latch Assembly 2 3/8" or 2 3/4" Backset	1
4	Inside Trim Plate Assembly	1
4a	Inside Chassis	1
4b	Inside Trim Plate	1
4c	#8-32 x 3/4" Flat Head Machine Screw	2
4d	9V Alkaline Battery	1
5	#8-32 x 1 1/2" Flat Head Machine Screw	2
6	#8 x 3/4" Wood Screw	4
7	Strike Plate	1
8	Security Plate	1
9	#10 x 3" Wood Screw	2

1. Door Prep

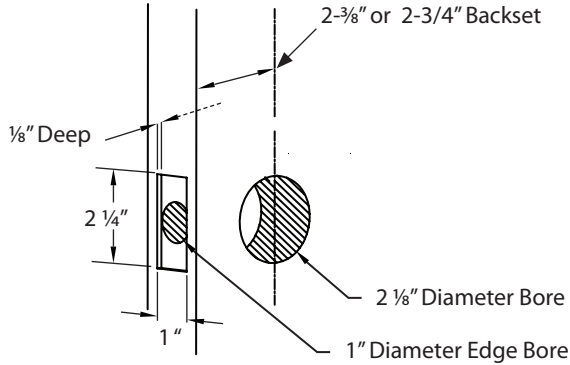

2. Door Jamb Prep

Step 1: Fasten Security Plate using two #10 x 3" Wood Screws (item #9).

Step 2: Fasten Strike Plate using two #8 x $\frac{3}{4}$ " Wood Screws (item #6).

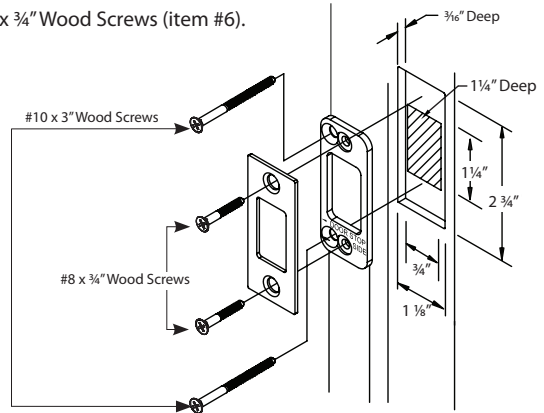

1. Install Latch

Fasten Latch using two #8 x 3/4" Wood Screws (item #6).



THE LATCH ASSEMBLY MUST BE ORIENTED AS SHOWN AND THE BOLT MUST BE IN THE RETRACTED POSITION FOR INSTALLATION.

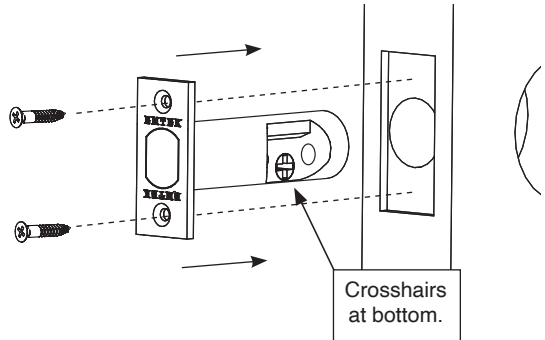
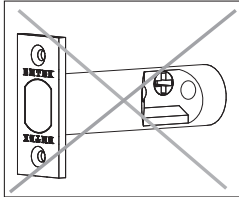

2. Remove Screws from Inside Trim Plate

Use a Phillips head screwdriver to remove screws (item #4c) shown below and detach Inside Trim Plate from the Inside Chassis.



REMOVE INSIDE CHASSIS FROM TRIM PLATE BEFORE INSTALLING THE OUTSIDE TRIM. THUMBTURN MUST BE IN UNLOCKED POSITION.

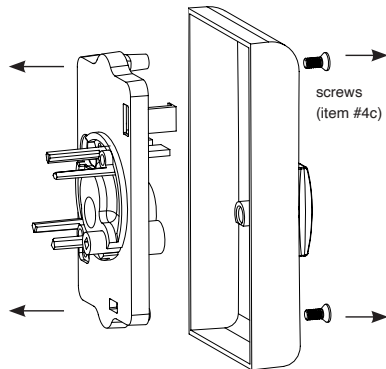
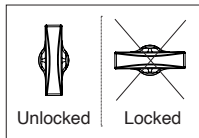

3. Install Outside Trim Plate Assembly

Position the Outside Trim Plate Assembly through the bore hole.



**ONCE POSITIONED,
OUTSIDE TRIM PLATE
ASSEMBLY REQUIRES
SUPPORT.**

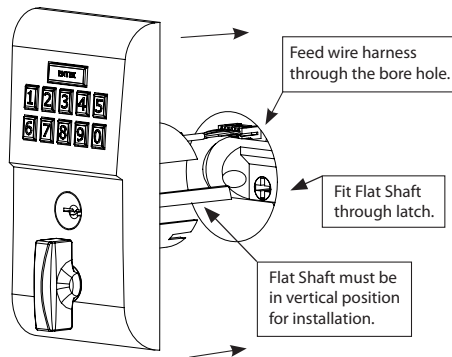

4. Install Inside Chassis

Step 1: Confirm the position of Flat Shaft.



**HOLE FOR FLAT
SHAFT MUST BE IN
VERTICAL POSITION
FOR INSTALLATION.**

✓ Correct for Installation.

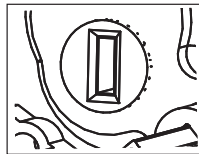

X Incorrect for Installation.

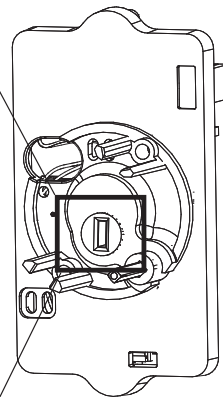
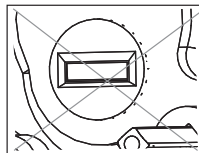

4. Install Inside Chassis

Step 2: Feed the Wire Harness through Inside Chassis.

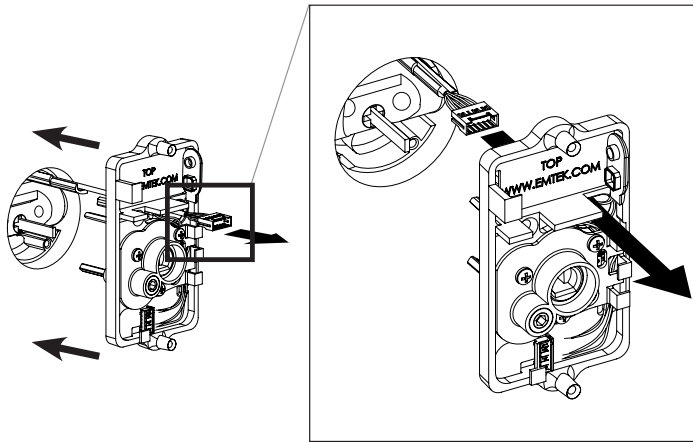

Step 3: Fasten Inside Chassis using two #8-32 x 1½" Flat Head Machine Screws (item #5).



CHECK ALIGNMENT BEFORE FULLY TIGHTENING SCREWS.

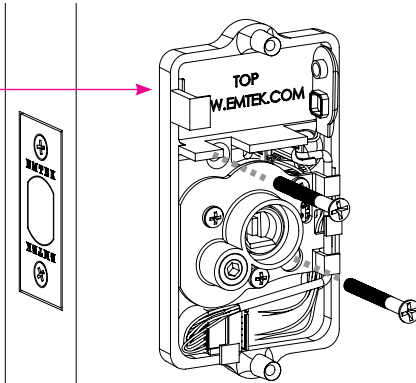

Step 4: Connect Wire Harness (A) and tuck Connectors as shown (B).

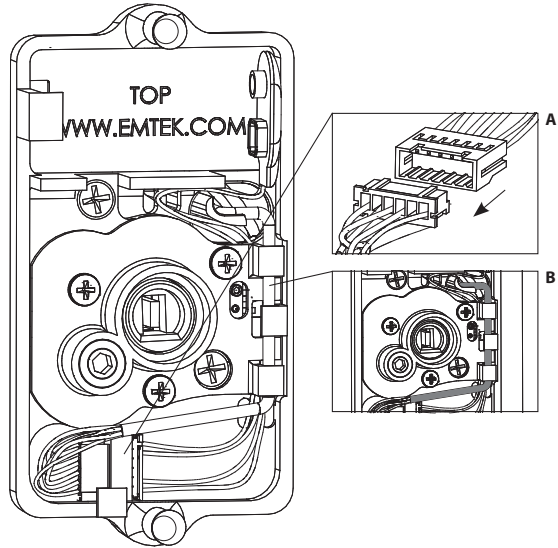

Step 5: Install Battery.

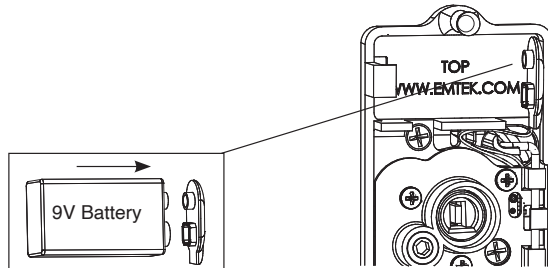

For optimal performance, always use a good quality battery.

5. Install Inside Trim Plate

Fasten Inside Trim Plate using two #8-32 x 3/8" Flat Head Machine Screws (item #4c).



**USER CODES
ARE LOCATED
ON THE INSIDE
TRIM PLATE &
ON PAGE 11.**

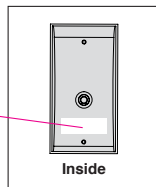

Correct for installation



*Unlocked

Incorrect for installation



Locked

*Unlocked position is required for installation and removal of the Inside Trim Plate Assembly.

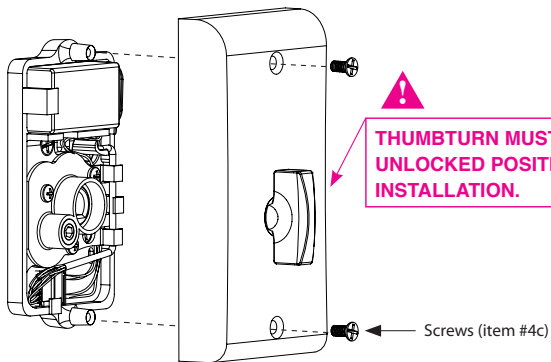

**THUMBTURN MUST BE IN
UNLOCKED POSITION FOR
INSTALLATION.**

Screws (item #4c)

Your Lock is Ready to Use

Your Emtek lock is shipped with two 4-digit user codes and a 6-digit programming code. These codes are randomly generated at the factory.
(Turn to next page for Programming Instructions.)

To Unlock:

1. Enter 4-digit user codes.
(See sticker located on the inside trim plate or on page 11).
2. Rotate Thumbturn.

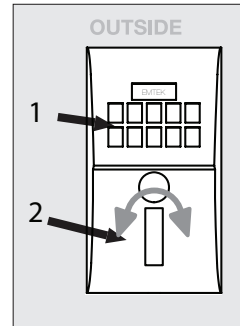

To Lock:

1. Press EMTEK key.
2. Rotate Thumbturn.

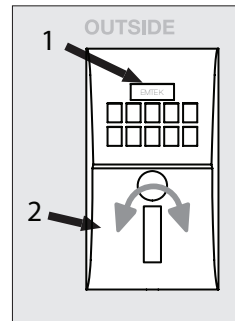

Programming Your Lock

In order to perform each of the following six functions, the lock must first be placed in Programming Mode:

1. Press and hold EMTEK button for 3 seconds
2. **Yellow** LED flashes, then remains solid*, number keys also illuminate
3. Enter Programming Code
4. **Yellow** LED flashes, then 1 beep
5. **Yellow** LED remains solid (awaiting button press; see following Table)

IF YOU WISH TO	PRESS BUTTON	ACTIONS		INDICATORS
Change Programming Code (6 digits)	1	Enter New Programming Code (6 digits)	Re-Enter New Programming Code (6 digits)	<ul style="list-style-type: none"> • 1 Green LED flash • 1 beep • 1 Green LED flash • 1 beep • 2 Green LED flashes • 2 beeps
Add User Code (4 digits) (Store up to 20 User Codes)	2	Enter New User Code (4 digits)	Re-Enter New User Code (4 digits)	<ul style="list-style-type: none"> • 1 Green LED flash • 1 beep • 1 Green LED flash • 1 beep • 2 Green LED flashes • 2 beeps
Delete User Code	3	Enter User Code to be Deleted	Re-Enter User Code to be Deleted	<ul style="list-style-type: none"> • 1 Green LED flash • 1 beep • 1 Green LED flash • 1 beep • 2 Green LED flashes • 2 beeps
**Enable/Disable All User Codes	4	Entering '4' disables all Users (enables all if disabled)		<ul style="list-style-type: none"> • 2 Green LED flashes • 2 beeps
Delete All User Codes	5	Re-Enter Programming Code		<ul style="list-style-type: none"> • 1 Green LED flash • 1 beep • 2 Green LED flashes • 2 beeps
Turn Beeper On/Off	6	Entering '6' turns OFF (or ON)		<ul style="list-style-type: none"> • 1 Green LED flash • 1 beep • 2 Green LED flashes • 2 beeps

*If no input within 10 seconds, **Yellow** LED goes out, **Red** LED flashes and lock exits Programming Mode.

**Also referred to as "vacation mode". This command temporarily disables all user codes (metal key override will still work).

Keypad Operation - Beeper & LED Indicators

Function	Indicators
Valid Code	• 1 short beep, EMTEK button flashes Green .
Invalid Code/Access Denied*	• 1 Red LED flash • 2 short beeps
Lock-Out Mode Error	• 2 short beeps • 1 short beep per second for duration
Access Accepted	• 1 short beep • 1 Green LED flash
Low Battery	• 4 Red LED flashes • 4 short beeps
Blackout Battery**	• 1 long Red LED flash • 4 long beeps
Button Press Accepted	• 1 Yellow LED flash • 1 Short Beep
Outside Thumb Turn Enabled	• 2 Green LED flashes

* If 3 consecutive incorrect codes are entered, the lock emits 4 short beeps and a flashing **Red** EMTEK button. The lock will not accept additional input for 20 seconds (20 beeps). When the next valid code is entered the lock will beep quickly 10 times to alert of the incorrect codes.

** Battery voltage has dropped too low; keypad will be disabled but metal key override will still work.

Restoring the Lock to Factory Default Setting

This procedure clears the lock of all users and restores the Programming Code and 2 User Codes shipped with the lock.

- Remove power (disconnect 9V battery) from Lock
- Press and Hold EMTEK button
- While continuing to hold EMTEK button, restore power (reconnect 9V battery)
- Continue to hold EMTEK button for 3 seconds
- 1 **Green** LED Flash and 2 short beeps followed by 1 **Green** LED Flash and 2 short beeps indicates the lock has been successfully restored

U.S. patents:
8,176,761
8,141,400

Canadian patents:
2,698,041
2,789,278
2,789,280

EMTEK®

Emtek Products

Tel: 800-356-2741 • 626-961-0413

Fax: 800-577-5771 • 626-336-2812

emtek.com



Place Sticker Here

Copyright © Emtek Products, ASSA ABLOY Residential Group Inc. DBA Emtek Products, 2021
Reproduction in whole or in part without the express written permission of Emtek Products is prohibited.

IN8-MODKEYPADDB

10/13/2021